

RCB 600 Quick Reference Guide

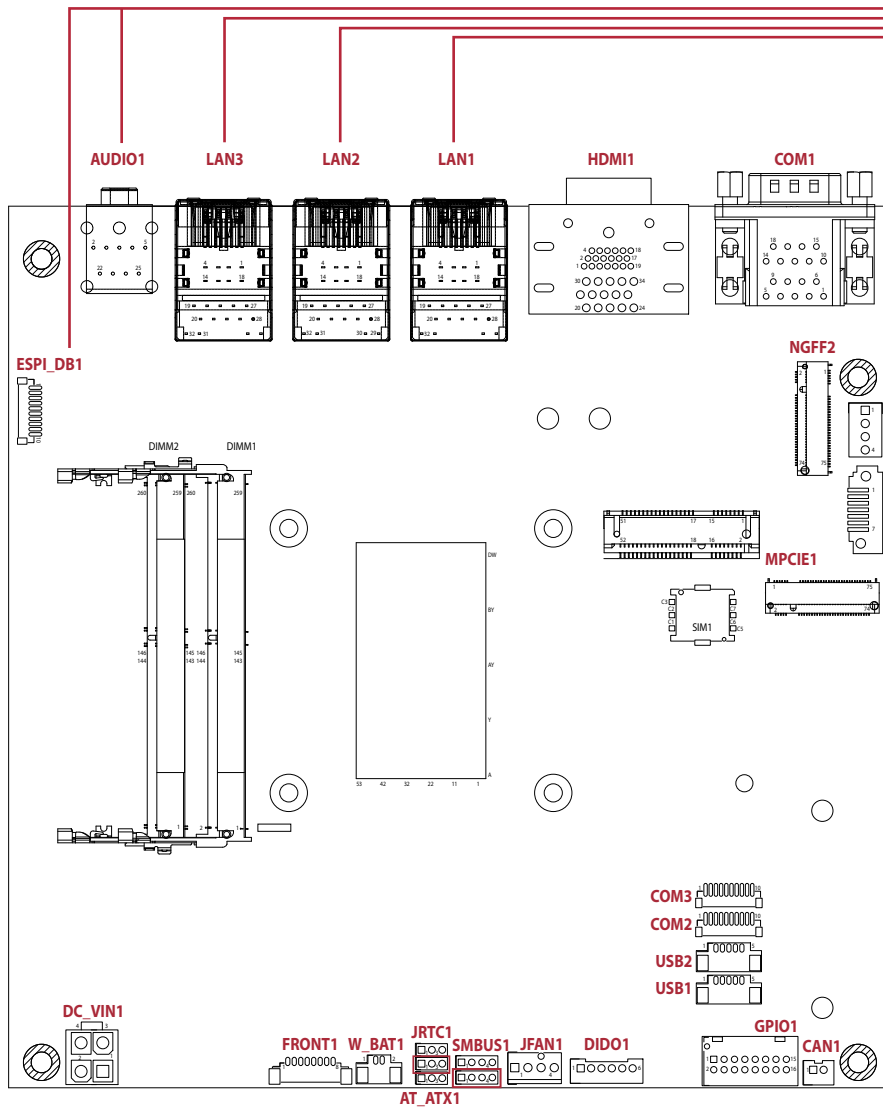

AUDIO1: Audio Phone Jack

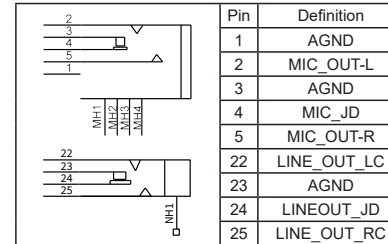

ESPI_DB1: Debug Connector

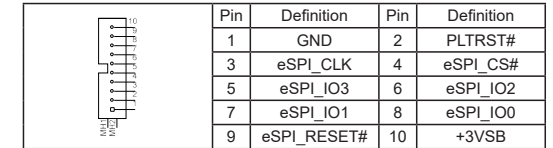

LAN3: 2USB 3.0 + LAN3 RJ45 Connector

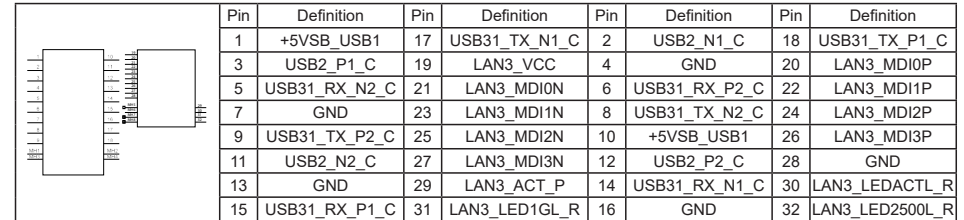

LAN2: 2USB 3.0 + LAN2 RJ45 Connector

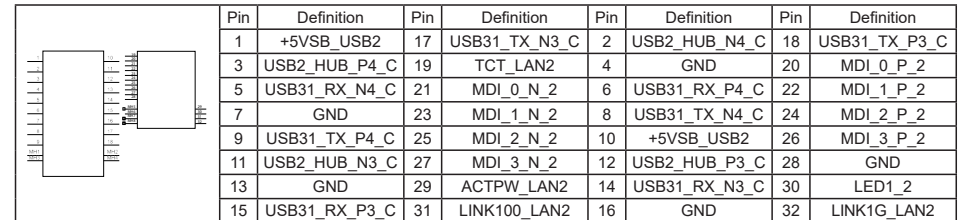

LAN1: 2USB3.0 + LAN1 RJ45 Connector

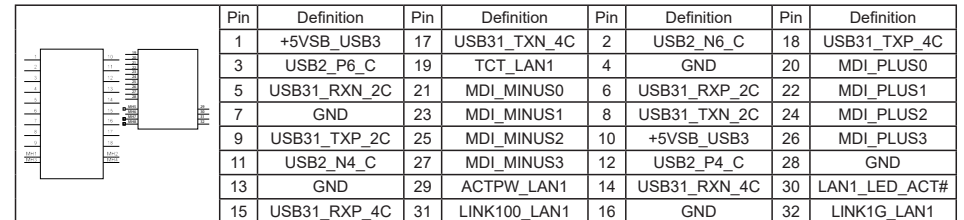

RCB 600 Quick Reference Guide

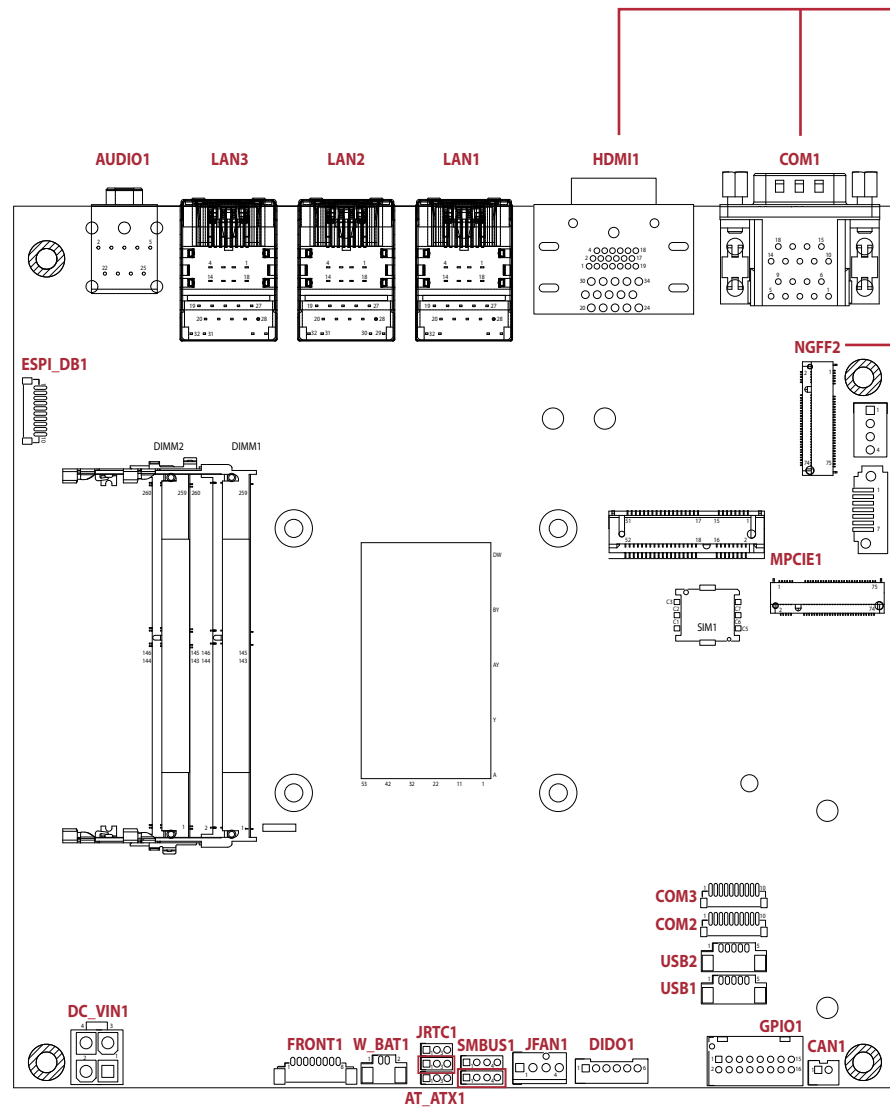

HDMI1: Display Connector

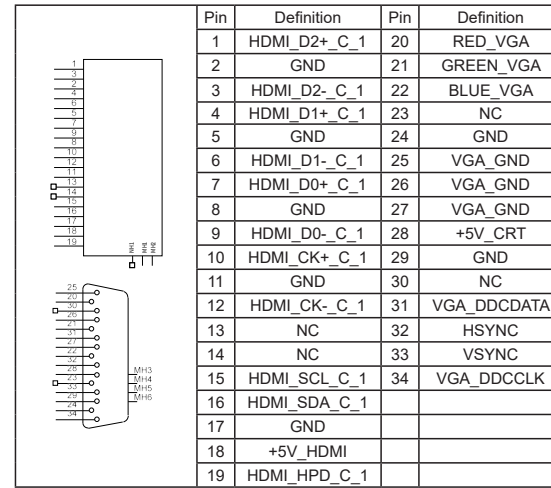

COM1: COM Port Connector

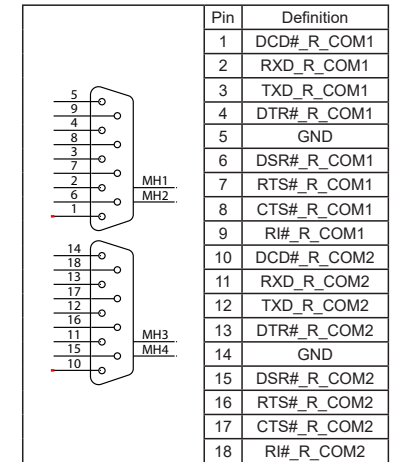

NGFF2: M.2 Key B Slot

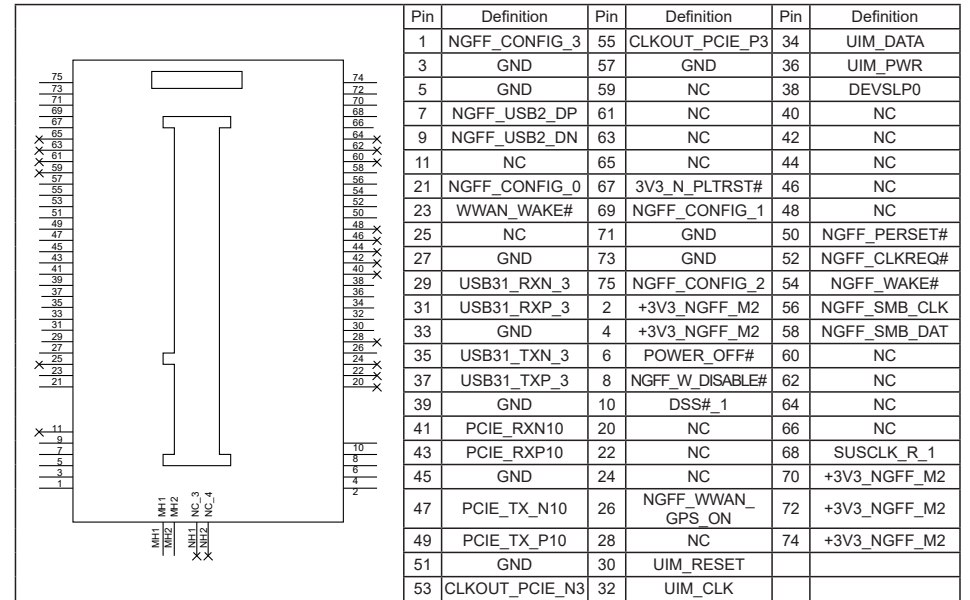

RCB 600 Quick Reference Guide

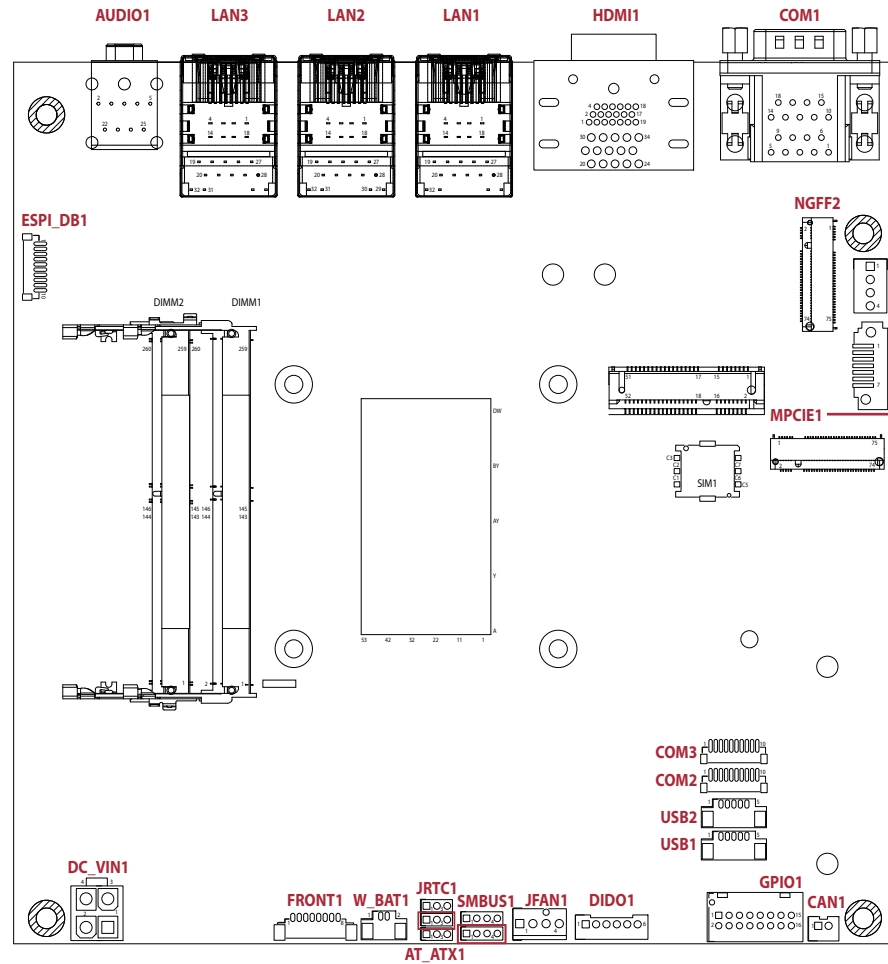

JSP1: SATA Power Connector

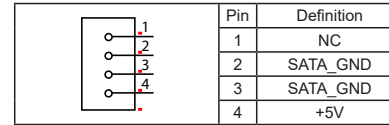

JSATA1: SATA Connector

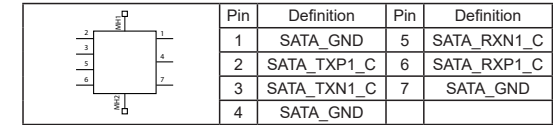

MPCIE1: mini-PCIe Slot

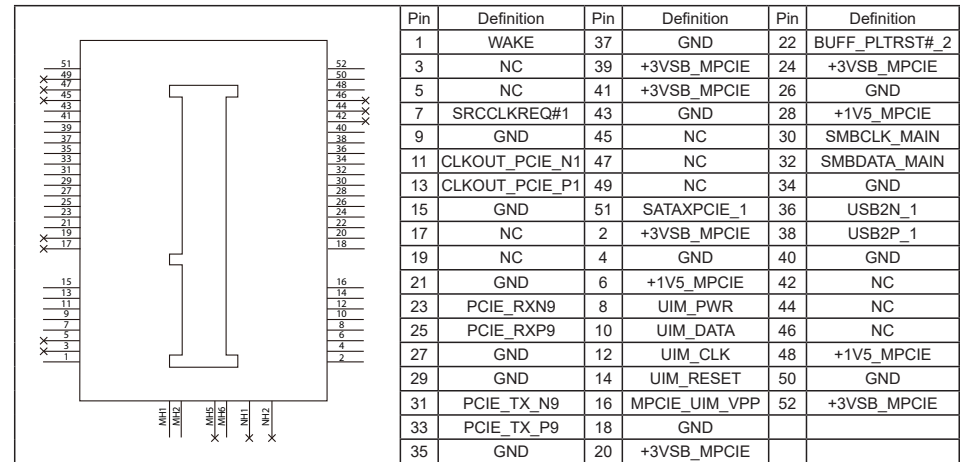

RCB 600 Quick Reference Guide

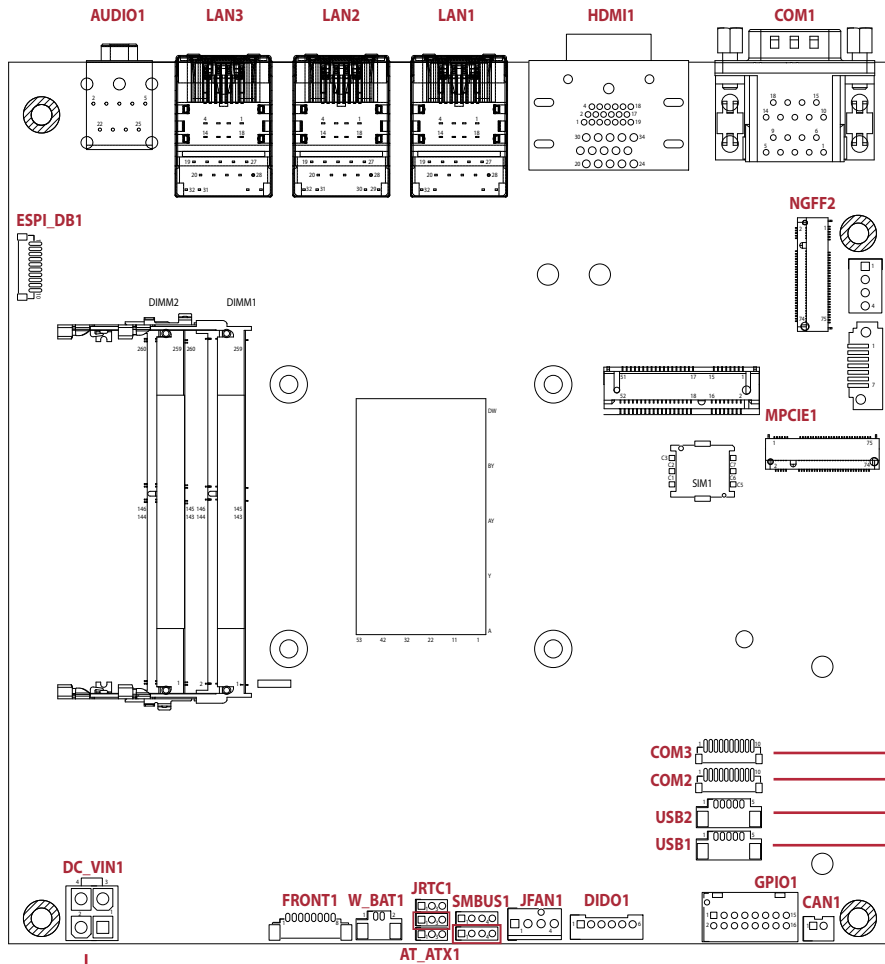

NGFF1: NGFF Key B Slot

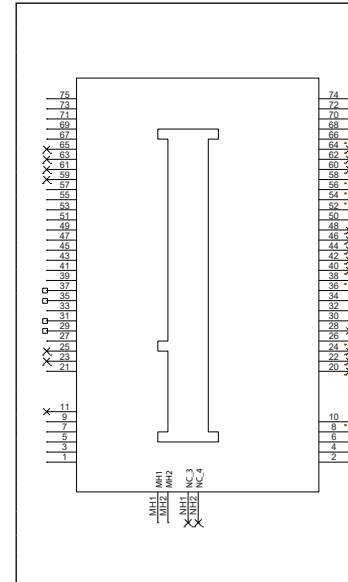

Pin	Definition	Pin	Definition	Pin	Definition
1	CONFIG_3	55	CLKOUT_PCIE_P4	34	NC
3	GND	57	GND	36	NC
5	GND	59	NC	38	NC
7	USB2_DP	61	NC	40	NC
9	USB2_DN	63	NC	42	NC
11	NC	65	NC	44	NC
21	CONFIG_0	67	3V3_PLTRST#	46	NC
23	NC	69	CONFIG_1	48	NC
25	NC	71	GND	50	N_PERSET#
27	GND	73	GND	52	N_CLKREQ#
29	NC	75	CONFIG_2	54	N_WAKE#
31	NC	2	+3V3_NGFF_M2B	56	N_SMB_CLK
33	GND	4	+3V3_NGFF_M2B	58	N_SMB_DAT
35	NC	6	POWER_OFF#_3.3V	60	NC
37	NC	8	W_DISABLE#	62	NC
39	GND	10	DSS#_1	64	NC
41	PCIE_RXP11	20	NC	66	NC
43	PCIE_RXN11	22	NC	68	SUSCLK_R_1
45	GND	24	NC	70	+3V3_NGFF_M2B
47	PCIE_TX_N11	26	N_WWAN_GPS_ON	72	+3V3_NGFF_M2B
49	PCIE_TX_P11	28	NC	74	+3V3_NGFF_M2B
51	GND	30	NC		
53	CLKOUT_PCIE_N4	32	NC		

COM2&COM3: COM Port Connector

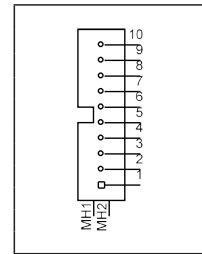

Pin	Definition	Pin	Definition
1	DCD#_COM4	1	DCD#_COM5
2	RXD_COM4	2	RXD_COM5
3	TXD_COM4	3	TXD_COM5
4	DTR#_COM4	4	DTR#_COM5
5	GND	5	GND
6	DSR#_COM4	6	DSR#_COM5
7	RTS#_COM4	7	RTS#_COM5
8	CTS#_COM4	8	CTS#_COM5
9	RI#_COM4	9	RI#_COM5
10	GND	10	GND

USB2: USB 2.0 Connector

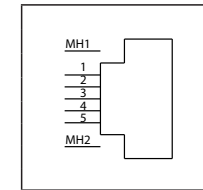

Pin	Definition
1	+5VSB_CN1
2	USB2_N5
3	USB2_P5
4	GND
5	GND
MH1	GND
MH2	GND

USB1: USB 2.0 Connector

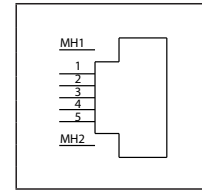

Pin	Definition
1	+5VSB_CN2
2	USB2_N8
3	USB2_P8
4	GND
5	GND
MH1	GND
MH2	GND

DC_VIN1: DC in Connector

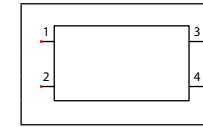

Pin	Definition
1	GND
2	GND
3	+24V
4	+24V

RCB 600 Quick Reference Guide

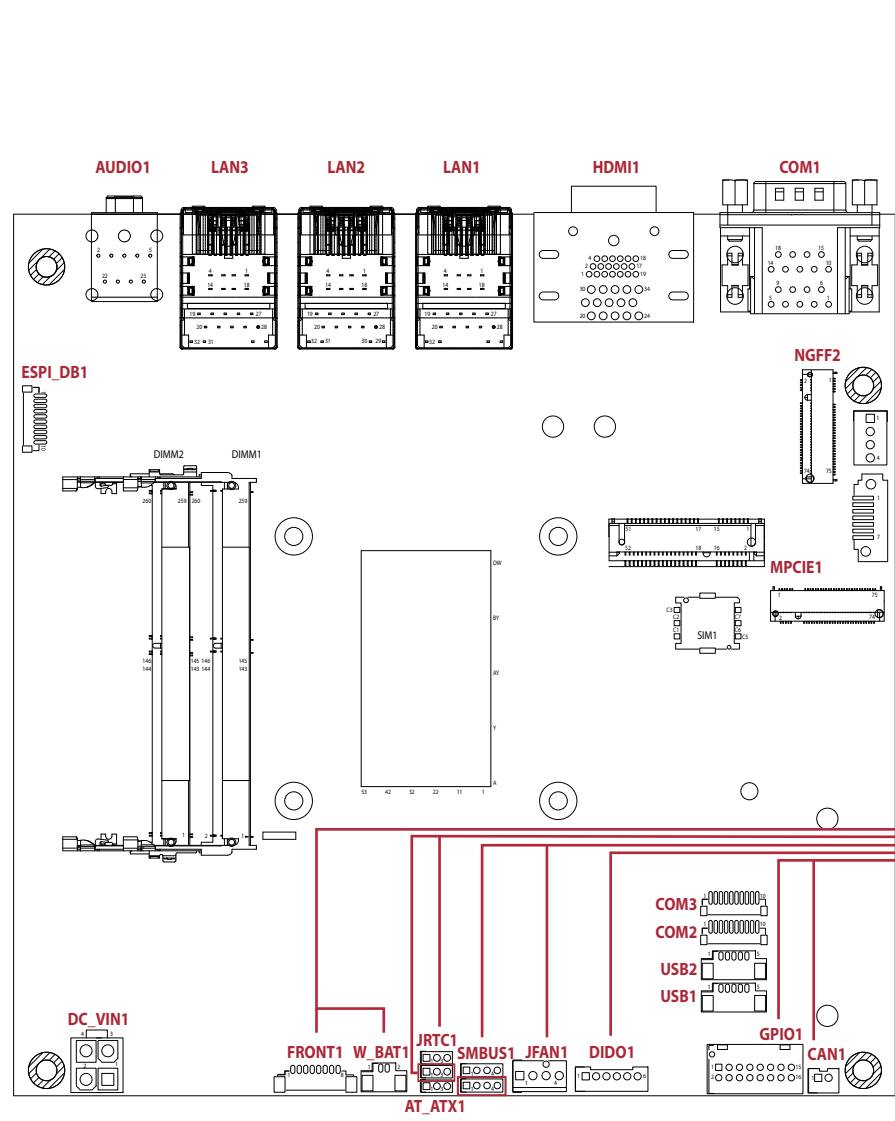

FRONT1: Front Panel

Pin	Definition
1	+3V3
2	HD_LED#
3	GND
4	SYSRESET
5	+3V3
6	PWRLED#
7	GND
8	ATX_PWRBT#

W_BAT1: RTC Battery Connector

Pin	Definition
1	GND
2	BATT+
MH1	NC
MH2	NC

AT_ATX1: AT/ATX Selection

Pin	Definition
1	AT_BTN (AT MODE)
2	PWRBTN#
3	ATX_BTN (ATX MODE)

JRTC1: RTC Clear Connector

Pin	Definition
1	+3VSB_RTC
2	RTCST#
3	GND

SMBUS1: SMBUS Connector

Pin	Definition
1	+5V
2	SML0DATA
3	SML0CLK
4	GND

JFAN1: CPU Fan

Pin	Definition
1	GND
2	12V_FAN
3	FAN_TAC1_C
4	FAN_CTL1_C

DIDO1: PIN Wire

Pin	Definition	Pin	Definition
1	OUTPUT0	2	OUTPUT1
3	G_O_COM0	4	G_I_COM0
5	INPUT0	6	INPUT1

GPIO1: PIN Wire

Pin	Definition	Pin	Definition
1	GPO_0	2	GPI_0
3	GPO_1	4	GPI_1
5	GPO_2	6	GPI_2
7	GPO_3	8	GPI_3
9	GPO_4	10	GPI_4
11	GPO_5	12	GPI_5
13	GPO_6	14	GPI_6
15	GPO_7	16	GPI_7

CAN1: PIN Wire

Pin	Definition
1	CAN1_L
2	CAN1_H

